

Z-5R NET 8000

RS-485 network controller with 8168 keys memory

User Manual

1. OVERVIEW

Z-5R NET 8000 controller is used to control access to residential and industrial areas, log access and other security events.

The controller can operate in standalone mode or as networked device.

Z-5R NET 8000 is equivalent to Z-5R in connections layout and standalone mode operation.

Z-5R NET 8000 is connected to network via RS-485 (2-wire connection).

Z-5R NET 8000 can work with the following equipment:

- Contactless card reader working via iButton (DS1990A emulation) or Wiegand-26 protocols;
- Contact key reader (iButton probe);
- Electromagnetic lock
- Electromechanical lock/latch;
- Door release button (normally open);
- External buzzer, external LED (same as the ones present on controller's PCB);
- Door sensor (normally open type).

Proximity card readers can be connected to the controller via iButton or Wiegand-26 protocols.

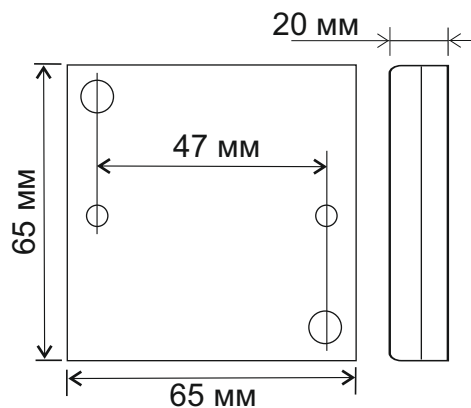

Figure 1: Device dimensions

2. CONNECTING AND MOUNTING

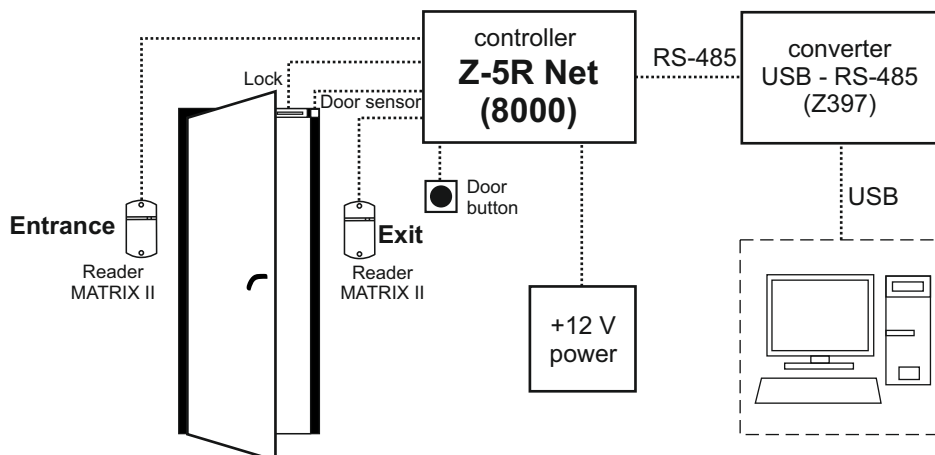

Figure 2: Z-5R NET 8000 Connections Layout

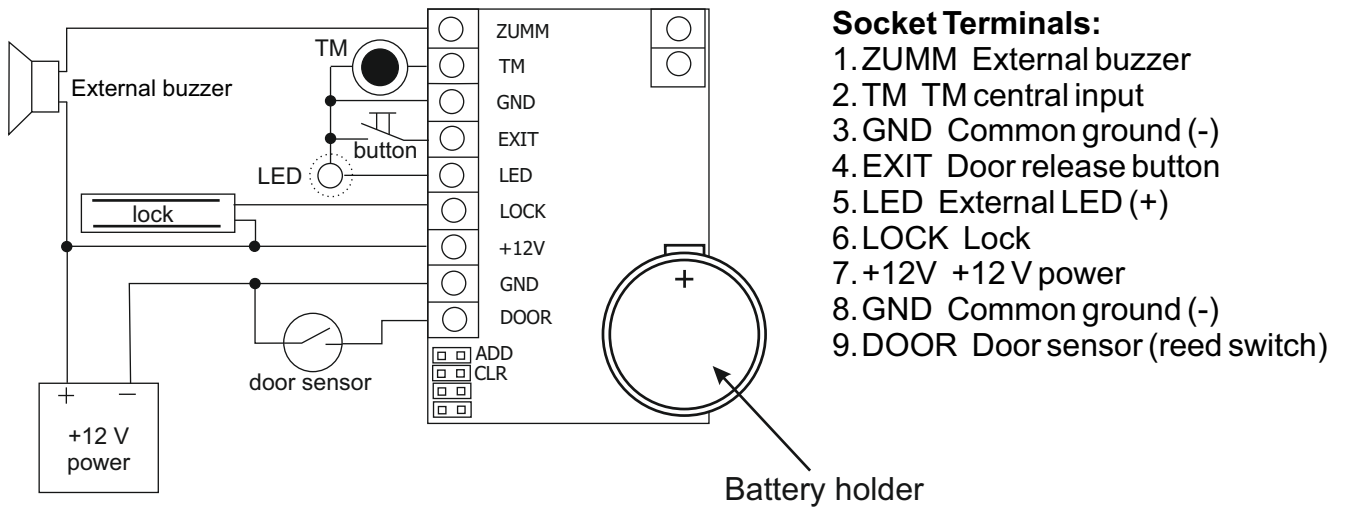

Figure 3. Connecting the accessories.

Note: External buzzer, LED and door opening sensor are optional elements.

Connecting readers via iButton (Dallas Touch Memory) .

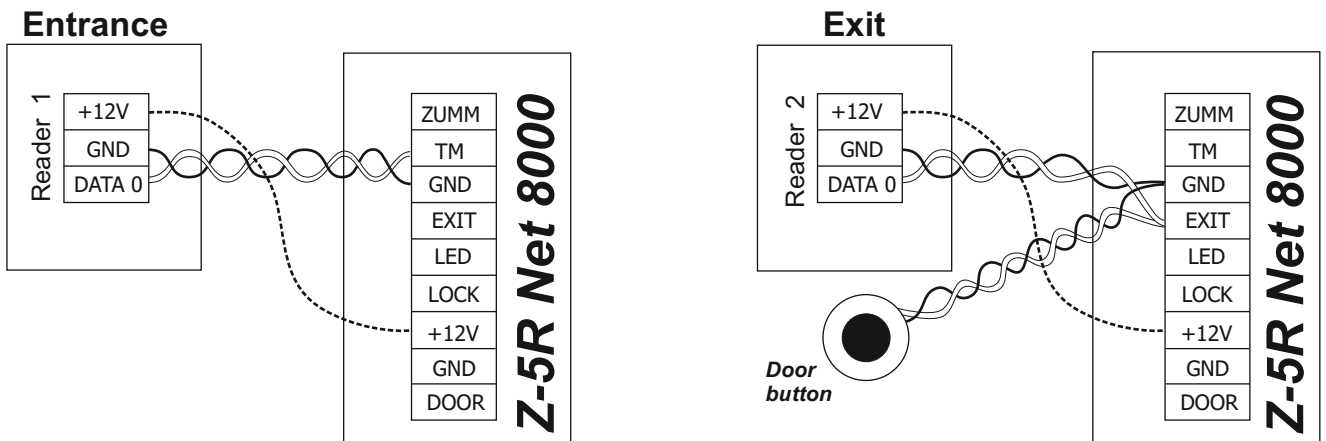

Figure 4. Connecting readers.

Note: To get the reader working at specified distance, please use a UTP cable, such as CAT5e:

- When connecting via iButton, one wire is connected to GND, another to DATA0 terminals.
- When connecting via Wiegand-26, first twisted pair is attached to GND and DATA0, and second to GND and DATA1.

Connecting readers via Wiegand-26.

Note: When connecting readers via Wiegand-26, ensure the jumper is connecting GND and LED terminals

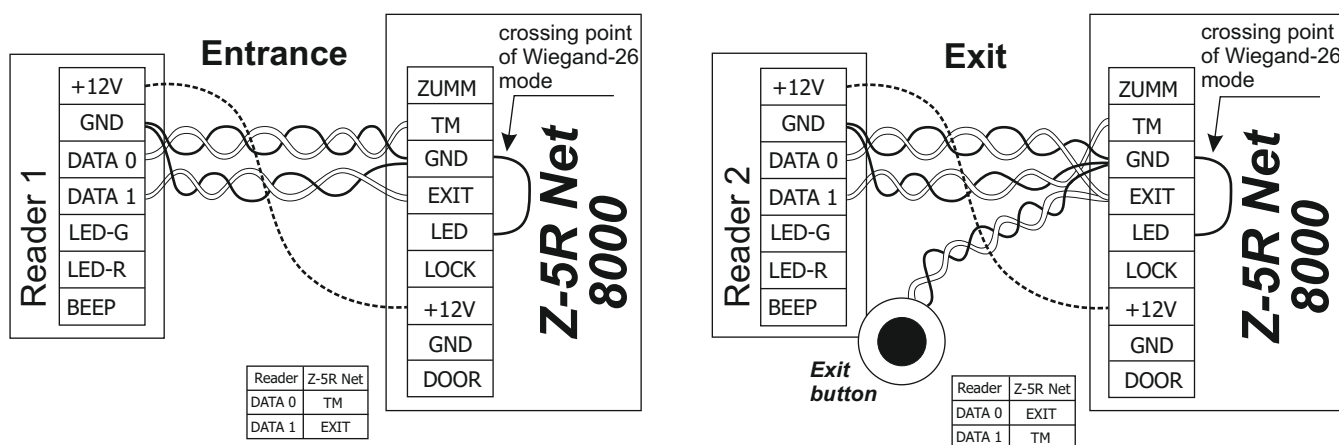

Figure 5. Connecting readers.

3. OPERATION

3.1 Programming the controller for standalone operation (no network).

Initial controller power-up (key database is empty).

Short beeps are emitted for 16 seconds, indicating that the key database is empty and Add Master Keys mode is activated. While the beeps are sounding, touch the probe with a key, and it will be written as new Master key. The beeping stops, acknowledging that first Master key is created successfully. To add more Master keys, keep touching the probe with more keys, leaving no more than 16 s between any two keys.

Each new key is acknowledged by a short beep.

To leave Add Master Keys mode, wait 16 s after the last key and it happens automatically, acknowledged by four short beeps in a row.

During further operation, the Master keys are used for programming; if none were yet successfully created, repeat the initial power-up procedure. Please note that the Add Master Keys mode is only activated on power-up if the controller's key database is empty (no Normal, Master or Blocking keys stored).

PROGRAMMING OVERVIEW.

To switch the controller into required programming mode, short (less than 1 s) and long (~6 s) Master key touches are used.

Each programming mode times out if the interval after the last key touch reaches the limit (~16 s). Then the controller returns to normal operation, confirming with a series of four short beeps.

1. Adding Simple Keys (1 M)

To switch the controller into required programming mode, short (less than 1 s) and long (~6 s) Master key touches are used.

Touch and hold the master key (long touch). At the moment of contact, the controller will issue a short signal confirming the master key identification, and after 6 seconds a second signal indicating the controller transition to the mode of adding simple keys. After that, the master key should be removed. To add new keys, touch the contactor in turn with a pause between touches for less than 16 seconds. For each contact with a new key, the controller issues a confirming short signal.

Table 1. Programming Modes

Modes	Mode Activation	Legend
Programming using Master keys		1...5 - number of touches. Letters denote Key type: N/n Normal Key B/b Blocking Key M/m Master Key
1. Add Normal Keys	1 M	
2. Add Blocking Keys	1 M	
3. Add Master Keys	1 m, 1 M	
4. Erase Single Keys	2 m, 1 M	
5. Erase All Memory	3 m, 1 M	
6. Set Door Opening Time	4 m	
7. Blocking Mode	1 B	
8. Accept Mode	5 m	Lowercase letter short touch (Key held <1 s)
Programming using Pins on Socket # 1		Uppercase letter long touch (Key held ~6 s)
1. Using Electromechanical Lock	Position 1	
2. Memory Erase	Position 2	
3. Add Normal Keys without a Master key	Position 3	
4. Normal - operation not affected	Position 4	

If the key is already in memory, then two short beeps. Exit from the mode either automatically after 16 seconds after the last touch, or when the master key touches it. The reader informs about the exit from the mode with a series of 4 short signals.

2. Adding blocking keys (1 M)

In the mode of adding simple keys, you need to touch the contactor with the selected key and hold it for about 9 seconds until a long signal (that is, first there will be a short signal and then a long signal to add a blocking key). If you do not add more keys, then there will be a series of short signals - exit from the programming mode.

3. Adding Master Keys (1 m, 1 M)

Briefly touch the contactor master key (short touch). At the moment of touching, the controller will generate a short signal confirming that the master key has been recognized, and within not more than 6 seconds touch and hold the master key at the contactor (long touch). At the moment of touch, the controller will issue two short signals indicating the second touch with the master key in programming mode, and after 6 seconds one signal indicating that the lock has entered the master key addition mode. After that, the master key should be removed. To add new master keys, touch the contactor in turn with a pause of no more than 16 seconds between touches. For each contact with a new key, the controller issues a confirming short signal. If the key is already in memory as a master key, then there will be no signals. Exit the mode of adding master keys automatically after 16 seconds after the last touch. The controller informs about the exit from the mode by a series of 4 short signals.

4. Erasing simple keys using a master key (2 m, 1 M)

Briefly touch the contactor's master key twice (short touches). At the time of the first contact, the controller will issue a short signal confirming the identification of the master key. At the moment of the second touch, the controller will issue two short signals indicating the second touch with the master key in programming mode, and no more than 6 seconds later, touch and hold the master key at the contactor (long touch). At the moment of the third touch, the controller will generate three short signals, and after 6 seconds, one signal indicating that the key has been erased. After that, the master key should be removed.

Take away the Master Key from the probe, and start touching it with the condemned keys one after another, with no longer than 16 s in between, to erase them one at a time.

The controller acknowledges each erase with a short beep. If the condemned key was not present in memory, two beeps will sound.

Leave this mode either automatically when 16 s have elapsed since last touch, or by a short Master Key touch. Exit is acknowledged by four short beeps in a row.

5. Erase All Memory by Using a Master Key (3m, 1M)

Touch the probe shortly three times with a Master key. The controller emits a short beep acknowledging the Master key, then on second touch, two short beeps, acknowledging second Master Key touch and entering programming mode. On the third touch, the Controller emits three short beeps, denoting third Master Key touch. Within 6 s after that, touch and hold the probe with the Master key (long touch). On the fourth touch, the controller emits four short beeps, and in 6 s, a series of short beeps, acknowledging that controller has erased its key memory entirely and left the programming mode.

Take away the Master key from the probe.

During the next power-up, the controller will enter programming mode automatically because the keys database is now empty.

Note: When erasing the entire keys database, the existing programmed Lock Opening Time setting is not reset.

6. Programming Door Opening Time (4m)

Touch the probe shortly four times with a Master key. The controller emits short beeps acknowledging the Master key touches, the number of beeps each time is equal to the number of Master Key touch.

On the fourth touch, the Controller emits four beeps and enters Door Opening Time programming mode.

Within 6 s after last touch, press the door release button for the period of time required to keep it open for. When the button is released, the controller beeps and stores the time the button was pressed to its memory.

Note: If door release button is not installed, please be sure to short-circuit the pins 3 and 4.

7. Blocking Mode (1B)

In Blocking mode, the Blocking keys are granted access, but Normal keys are denied access. Blocking mode is activated via a Blocking key (see p.2 on creating Blocking keys).

The Blocking keys are used as following:

- As a Normal key during normal operation (when access is granted for both Blocking and Normal keys present in the database).
- To activate Blocking mode (where only Blocking keys are granted access).
- To leave the Blocking mode and revert to Normal mode.
- The Blocking key opens the door when it is taken away from the probe.

To activate the Blocking mode, please touch and hold the probe with a Blocking key for about 3 s until a long continuous tone begins to sound, acknowledging the Blocking mode.

In this mode, any Normal keys are denied access and a series of short beeps sounds instead.

To deactivate Blocking mode and revert to normal operation, touch the probe shortly with a Blocking key or a Master key, waiting for a series of short beeps to acknowledge that Blocking mode is deactivated.

Note: If the supply power fails while Blocking mode is active, the Blocking mode is still on after the power is back on.

8. Accept Mode (5m)

Accept mode writes all DS1990A keys touching the probe, into controller memory. In this mode, when a key touches the probe, the door is unlocked and also the key is stored into keys database in controller memory. This mode is used to restore the controller keys database without having to gather back all the keys issued to users. A Master key is necessary to activate this mode.

Touch the reader five times shortly with a Master key. On each touch, the controller will acknowledge the Master key, emitting the number of short beeps equal to the number of touch (one for first touch, two for second etc.). On fifth touch, the controller will emit five short beeps and in 5 s, an additional long beep, acknowledging Accept mode activation.

To deactivate Accept mode afterwards, touch the reader with a Master key again; a series of short beeps will acknowledge exit from this mode.

Note: If the supply power fails while Accept mode is active, the Accept mode is still on after the power is back on.

USING JUMPER 1 (Figure 6)

The controller comes with a jumper block for programming.

Position 1 - sets the lock operational logic:

- jumper open (by default), electromagnetic lock (normally open)
- jumper closed, electromechanical lock (normally closed)

Position 2 (CLR) - to erase (clear) the Controller memory. To do so, please power it OFF, install the jumper and power it back ON. When memory erase is complete, a series of short beeps sounds.

Note: This will erase the entire keys database along with the custom Opening Time setting. The Opening Time gets reset to factory default (3 seconds).

Position 3 (ADD) - to add Normal Keys without a Master Key. To do so, please power the Controller OFF, install the jumper and power it back ON. A signal acknowledges Add Normal Keys mode. Both Normal and Blocking Keys can be now added without a Master Key.

After 16 seconds of no Key touches, a series of short beeps will sound, acknowledging exit from the Add Normal Keys mode.

Position 4 - default position, controller operation not affected.

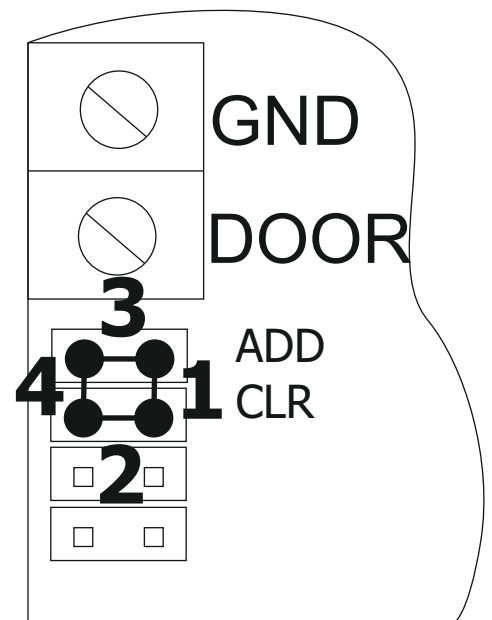

Figure 6. Possible jumper positions.

3.2 Networked Operation.

Controllers Z-5R Net 8000 can be networked via RS-485 interface and operate under control of control software running on a PC. Specialised software (described in detail on company website) allows for controllers programming, operation control, event log downloads. However, the access decisions are still made by the controller, be it standalone or networked.

Controllers are sequentially chained, one after another. See potential way of connecting controllers to a PC on Figure 7.

“Last” Controller means that it is physically last on a bus. Controller logical number (address) on the network is configured via software. Initially all Controllers come configured with logical network address 1. If more than one controller is present on the network, they must be assigned new logical network addresses.

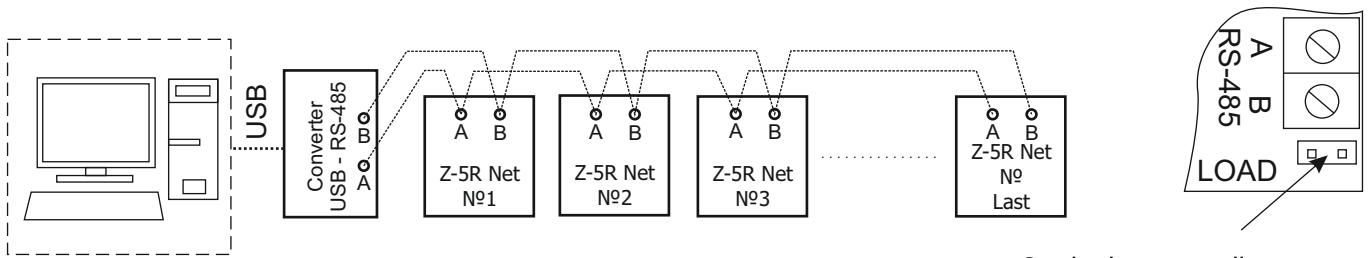

Figure 7. Connecting Controllers to a PC.

On the last controller the jumper is shorted on a receptacle Nº2 (LOAD)

4. SPECIFICATIONS

- Maximum supported Keys number:8,168;
including:
 - Normal Keys for passing the door,
 - Master Keys for programming,
 - Blocking Keys for Blocking Mode (can double as Normal Keys).
- Lock type choice jumperPresent;
- Lock opening time range:0.1...25.5 sec. (factory pre-set to 3.0 sec.);
- Power supply voltage:12 V DC;
- Standby current:30 mA;
- Protection from incorrect connection:Present;
- Indication of operation and programming modes:Audial and visual;
- External interface:RS-485;
- Link distance to remote controller via RS-485:max 1,200 m;
- Power output:Field effect transistor, up to 5A;
- Case material:ABS plastic;
- PCB dimensions, mm:60 x 50 x 12;
- Weight:80 g.

Z-5R NET 8000 Networked operation specifications.

- Maximum cards/keys number: 8,168;
 - Event log memory: 8,192;
 - Maximum Controllers on the network: 255;
 - RS-485 baud rate: 19,200/57,600 bps (negotiated automatically).
- If a door sensor is present, additional events “Door broken in” and “Door not closed” become available. To avoid real-time clock failure in case of power failure, install a 3V CR2032 lithium cell battery into the battery socket (as per Figure 3).
Controller network logical address is initially set to 1.

Additional operation modes:

- Blocking mode access granted only to Blocking keys, but to Normal keys access is denied.
 - Accept mode all keys used are granted access and also are stored into key database.
- These modes are activated by a Master Key.

5. OPERATING CONDITIONS

Ambient temperature:5...40°C.
Humidity:up to 80% at 25°C.

Controller specifications may differ from described here, when operating under non-recommended conditions.

The controller should be operating in absence of: atmospheric precipitation, direct sunlight, sand, dust, and moisture condensation.

6. PACKAGE

- Z-5R NET 8000 controller1
- Case1
- Jumper block1
- CR2032 (watch type) battery1

7. LIMITED WARRANTY

This Device is covered by limited warranty for 24 months.

The warranty becomes void, if:

- this Manual's guidelines are not followed;
- the device has suffered physical damage;
- the device has visible traces of exposure to moist and/or aggressive chemicals;
- the device circuits have visible traces of tampering by unauthorised parties.

Under this warranty, the Manufacturer shall repair the device or replace any broken parts as required, free of charge, in cases where the fault is caused by a Manufacturer's defect.

8. CONTACTS

Authorized representative in the European Union:

ICONCONTROL SIA

1B Balta Street, LV - 1055, Riga, Latvia

E-mail: info@iconcontrol.lv

Phone: +371 24422922

www.iconcontrol.lv



The symbol of crossed-through waste bin on wheels means that the product must be disposed of at a separate collection point. This also applies to the product and all accessories marked with this symbol. Products labeled as such must not be disposed of with normal household waste, but should be taken to a collection point for recycling electrical and electronic equipment. Recycling helps to reduce the consumption of raw materials, thus protecting the environment.

