

Z-7 EHT RFID Electronic Door Lock

with EM-Marine & HID ProxCard II & Atmel (T5557) reader (125 kHz)
and standalone controller

User Manual

1. OVERVIEW

Z-7 EHT lock consist of a wireless reader, a locking system and a controller powered by four 1.5V AA batteries). From outside, the door opens by approaching with a card, and from inside, it's enough to just turn the door handle.

Z-7 EHT locks have two operating modes.

- OFFICE MODE: Only cards in the lock's controller database can open the lock. With special software, it is possible to limit card access by time of day and day of week.
- HOTEL MODE: Considers the security and operation requirements of hotels, guest houses, dorms, student campuses etc. Allows creating "Guest Cards", "Staff Cards", "Special Cards", which are assigned specific access rights and offer protection against card cloning or loss. The Hotel Mode operates only with special software.

2. SPECIFICATIONS.

- Work Frequency: 125 kHz;
- Keys standards:EM-Marine, HID ProxCard II, Atmel (T5557);
- Maximum number of keys/cards: 1364;
- Maximum Event Log capacity: 1000;
- Inbuilt NVRAM: Present;
- Reading Distance: 2...4 cm;
- Standby mode current: 30 μ A;
- Power: Four 1.5 V AA batteries;
- Audio-visual status indication: buzzer signal, two LEDs;
- Door Unlock Duration settings: 0...220 s;
- Working ambient temperature: +5...+40 °C (except batteries);
- Case material: Stainless steel;
- Case colours: Silver, Gold.

3. ASSEMBLY AND MOUNTING

To assemble and mount the lock, you will require the following:

- 1) Drill
- 2) Hammer
- 3) Chisel or core drill (Unibit).
- 4) Wood spade bits, 36 and 20mm.
- 5) Wood drill bit, 12 mm.
- 6) Hex socket wrench, 2.5 mm, to fix the secret part.
- 7) Philips screwdriver.
- 8) Torx wrench T27 (to change the lock handle direction).

1. Using woodwork tools, prepare the door and door frame to install the lock. Use the template in Fig.9 to mark the locations and sizes of holes on the door.
2. Install the lock as per Fig. 2.
3. Install metallic latch cover over the latch and fix it to the door frame, see Fig. 4.
4. Program the lock (see Chapter 4, START-UP)
5. Install the outer lock covers over the lock, see Fig. 3.

3.1. Changing the lock handle direction (left/right door).

In factory configuration, the lock covers arrive with the lock handle set for the right-hand door, the handle points to the right. If necessary, change the lock handles direction, carefully unscrewing the fixing screw on the handle by a T27 torx wrench. See Fig. 1 and Fig. 1.1.

The design of handle assembly does not imply for screwing the star-shaped fixing screw with significant effort; this will lead to no leeway for the lock handles. So use "fixing liquid" (or super-glue) before installing the star-shaped fixing screw. Details you can see on Fig. 1.

3.2. Changing the lock direction (left/right door).

In factory configuration, the mechanical lock comes set to use with a right-hand door. To install the lock onto the left-hand door, please swap the bushings. See Fig. 1.2.

To prevent mistakes, use the following rules to select the places for bushings:

- The blackened (anodized) bushing must always be paired with the lock cover on the side where the reader is located (external cover).
- The silver bushing must always be paired with the lock cover on the side where battery compartment is located.

3.3. Change the door direction (inside/outside)

In factory configuration, the silver coloured mechanical lock is configured for an outside door, and the gold coloured lock for the inside door.

If necessary, change the latch direction as follows:

- 1) Remove the lock cover.
- 2) Remove the latch spring.
- 3) Rotate the latch 180 degrees.
- 4) Install the latch spring back.
- 5) Fix the lock cover.

Please use Fig. 1.3 to assemble the lock.

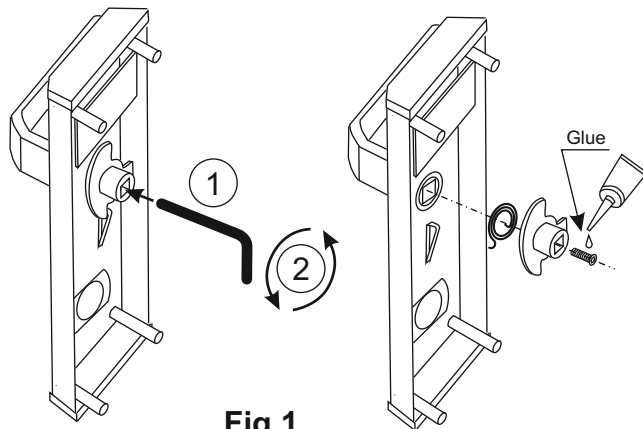

Fig.1

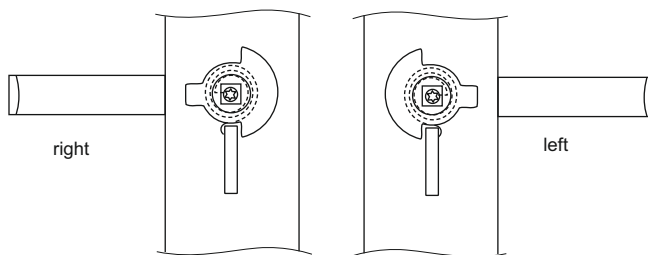

Fig.1.1

Attention!
The black triangle is
always pointed
towards the tongue
(as in the figure).

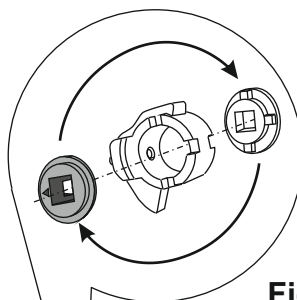

Fig.1.2

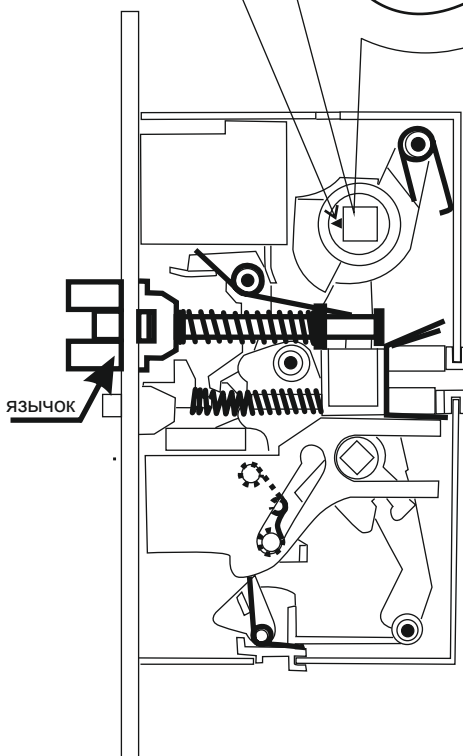

Fig.1.3

Requirements for the door dimensions:
 A = 40-50 mm
 B = min 100 mm

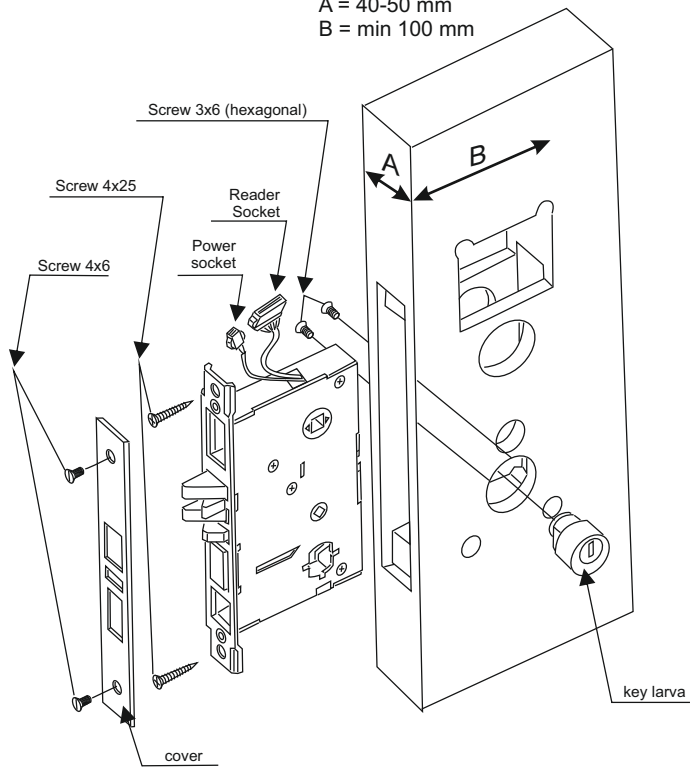

Fig.2

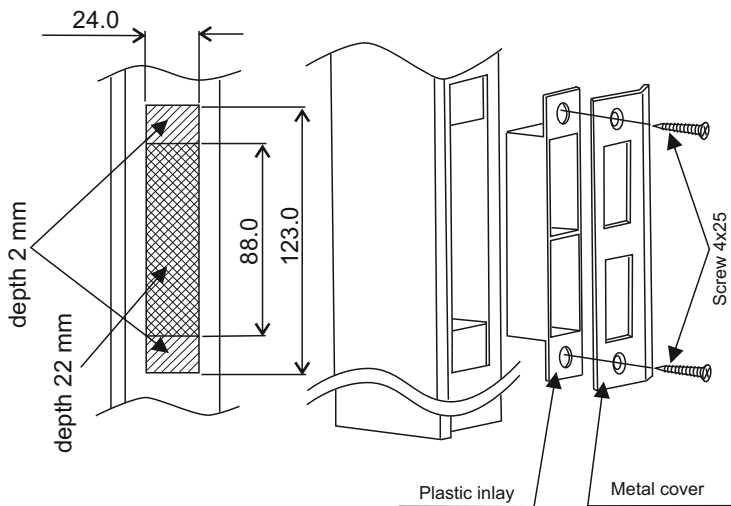

Fig.4

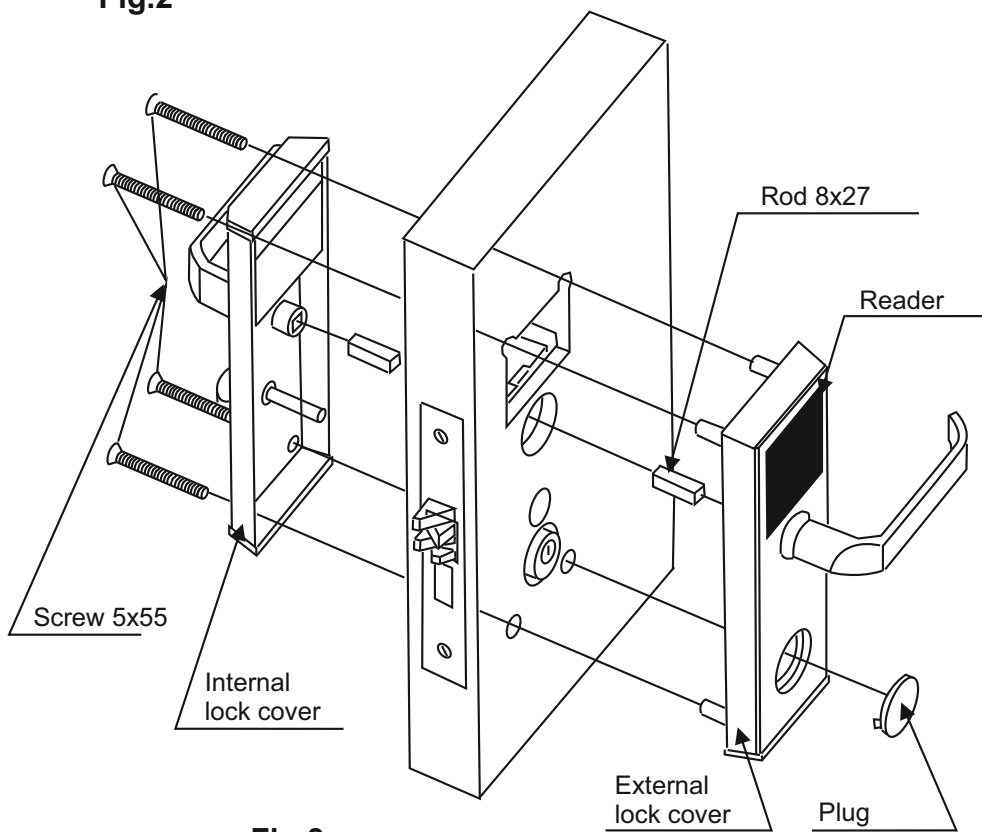

Fig.3

4. OFFICE MODE: OPERATION AND PROGRAMMING

The key/cards database is created by means of a Master card or a computer, then stored into lock's controller memory. The door is always closed; when a valid card is presented, a beep sounds and the blue LED is blinking. While the blue LED is blinking, lock handle can be turned to open the door. The lock is automatically closed again after the handle is released, or after 3 seconds.

When the card has no access rights, a beep sounds and the red LED is blinking. The door doesn't open when the lock handle is turned.

To leave the room from inside, just push the lock handle.

To assign a Master card, initial power-up state must be active (No cards stored in lock's memory).

Initial Power-up (No cards stored in lock's memory yet).

Set the jumper on the reader's printed circuit board (PCB) to Position 1 (See Fig. 5). Connect the reader's PCB module to the locking module using the 8-pin socket. Minding the polarity, insert four AA batteries into the battery compartment. Connect the 2-pin socket on the battery compartment to corresponding part on the locking module.

When power is supplied to the lock, it keeps beeping and its blue LED is flashing for 16 s, thus indicating that lock's memory is empty and it is ready to store a Master card. While the beeps are still sounding (within 16 s) approach a card to the reader, -- this card will be stored into lock's memory as a Master card. The beeps will cease, confirming that the first Master card was successfully stored. To add more Master cards, approach them one by one to the reader, keeping the interval between cards less than 16 s. Each touch by a new card the reader will confirm by a short beep.

Exit from Add Master Cards mode happens automatically at 16 s after the last approach. Exit from Add Master Cards mode is confirmed by a series of five short beeps.

If no cards could be stored as Master cards, just turn the power on again later. The Add Master Cards procedure described above can only be used when lock's memory is empty. Subsequently, use the Master card(s) you've created for programming.

To use programming functions, use short (< 1 s) and long (~ 6 s) touches by Master card. There is a limit, 16 s after the last touch, in programming mode; once it expires, the reader reverts to normal mode, confirming that with five short beeps.

Cards Hierarchy

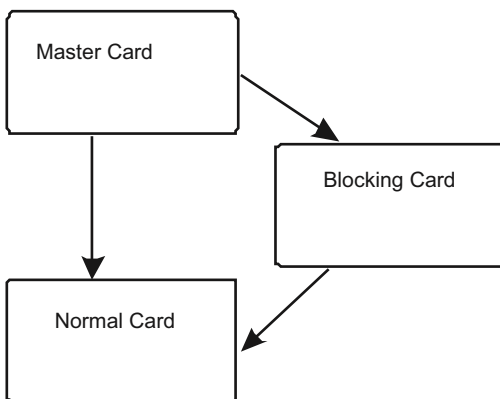

Master Card - card for service needs only.

- Adds and removes Normal and Blocking cards.
- Turns on and off Accept mode.
- Turns off Blocking mode.
- Creates additional Master cards.

Blocking Card - access card.

- Can block/resume access for Normal cards.
- Turns on and off Free Access mode and Blocking mode.

Normal Card - access card only.

Table.Programming Functions in OFFICE MODE.

Programming using Master cards		
Add Normal Cards	1M	1...5 – Number of touches. Lowercase letter (m) – short touch (hold for < 1 s) Uppercase letter (M) – long touch (hold for ~ 6 s) <u>Letters:</u> M – Master Card B – Blocking Card N – Normal Card
Add Blocking Cards	1M	
Add Master Cards	1m, 1M	
Erase Normal Cards	2m, 1M	
Erase All Cards (from controller memory)	3m, 1M	
Set Door Release Time	4m	
Blocking Mode	1B	
Accept Mode	5m	
FreePass Mode	Handle Down, 1B	
X1 Socket Jumpers Designation.		
OFFICE MODE	Position 1	See Paragraph 6
Add Normal Cards with no Master Card – OFFICE MODE	Position 2	
Erase All Memory – OFFICE MODE	Position 3	
HOTEL MODE	Position 4	
The whole X1 socket is used, when working with Z-2 EHR Adapter, to load keys database from computer.		
Programming with Z-2 USB RF-1996 adapter		
Store lock's controller memory onto a RF-1996 adapter	1m, 1M	See Paragraph 11
Load keys database from a RF-1996 adapter into controller memory.	Initial Power-up or when controller database is empty, Or 1M	

Programming Using a Master Card in OFFICE MODE.

4.1. Add Normal Cards (1M)

Touch and hold a Master card (long touch). On touch, the reader issues a short beep acknowledging the Master card, and in 6 s, a second beep indicating that reader has entered Add Normal Cards mode. Now remove the Master card from the reader.

To add new cards, touch them to the reader one after another, with intervals between touches ≤16 s. Each new card touch is acknowledged by a short beep. If a card is already present in memory, two short beeps are issued. Exit from this mode happens either automatically, in 16 s after the last touch, or after a Master card touch. The reader confirms the exit with a series of five short beeps.

4.2. Add Blocking Cards (1M)

In Add Normal Cards mode, touch your card to the reader and hold for ~ 9 s, until a long beep (i.e. a short beep first sounds, then this long beep acknowledging Add Blocking Cards mode). If you don't add any more cards, a series of short beeps will indicate exit from the programming state.

A Blocking card has the following functions:

- Serves as a Normal card during Normal Mode (when all Blocking and Normal cards stored in the database have access);
- Switches to Blocking mode (when only Blocking cards have access);
- Switches to Free Pass mode (using just the door handle, no cards required);
- Switches to Normal mode;
- Allows to open the door, if someone locked themselves out from inside.

4.3. Add Master Cards (1m, 1M)

Touch the reader with a Master card (short touch). On touch, the controller issues a short beep acknowledging the Master card; then within 6 s touch and hold the Master card at the reader (long touch). On touch, the reader issues two short beeps denoting the second Master card touch in programming mode, and in 6 s, a beep acknowledging Add Master Cards mode. Now remove the Master card from the reader.

To add more Master cards, keep touching the reader with them one after another, with intervals between touches ≤ 16 s. Each new card touch is acknowledged by the reader with a short beep. If a card is already stored in memory as a Master card, no signals are issued. Exit from this mode happens automatically, in 16 s after the last touch. The reader confirms exit with a series of five short beeps.

4.4. Erase Normal Cards with a Master Card (2m, 1M)

Touch the reader with a Master card twice (short touches). On first touch, the reader issues a short beep acknowledging the Master card. On second touch, the reader issues two short beeps, denoting the second Master card touch in programming mode; then within 6 s touch and hold the Master card at the reader (long touch). On third touch, the reader issues three short beeps, and in 6 s, a beep indicating transition to Erase Normal Cards mode. Now remove the Master card from the reader.

To erase cards, touch the reader with them one after another, with intervals between touches ≤ 16 s. Each card touch is acknowledged with a short beep. If the card was not present in memory, two short beeps sound. Exit from this mode happens either automatically, in 16 s after the last touch, or after a Master card touch. The reader confirms the exit with a series of five short beeps.

4.5. Erase All Memory (3m, 1M)

Touch the reader with a Master card three times (short touches). On first touch, the reader issues a short beep acknowledging the Master card. On second touch, the reader issues two short beeps, denoting the second Master card touch in programming mode. On third touch, the reader issues three short beeps, denoting the third Master card touch, and within 6 s touch and hold the Master card at the reader (long touch). On fourth touch, the reader issues four short beeps, and in 6 s, another series of short beeps, indicating the erasure of entire reader memory and exit from the programming mode. Now remove the Master card from the reader; the Programming mode will be automatically re-entered after next power-up.

Note: When erasing the whole database using a Master card, the programmed Door Release Time is NOT reset.

4.6. Programming Door Release Time (4m)

Touch the reader with a Master card four times. On each touch, the controller issues beeps acknowledging the Master card touches, their number corresponding the number of touch. So on fourth touch, the controller issues four beeps and enters the Door Release Time Programming mode. Within 6 s after the last touch, turn down the internal lock handle and hold it for the exact time you want to set as door release time. During door release time programming the blue LED will keep flashing. When the lock handle is released, the controller issues a beep and stores the measured time into its memory.

4.7. Blocking Mode (1B)

In the Blocking mode, access is granted for Blocking cards only, but denied for Normal cards. The Blocking mode is activated by a Blocking card (see p. 4.2 about how to Add Blocking Cards).

To enter the Blocking mode, hold the Blocking card at the reader for ~ 3 s, until a long, continuous beep starts sounding, -- that will denote the Blocking mode turned on. In this mode, all Normal cards are denied access: the lock fails to open, only issuing a series of short beeps. To exit the Blocking mode and revert to Normal mode, either:

- a) Use a Blocking card in the same way as when entering Blocking mode (until a series of short beeps);
- b) Touch the reader with a Master card (until a series of short beeps).

Note: In case of power failure, the state of Blocking mode is preserved after the power is back.

4.8. Accept Mode (5m)

The Accept mode stores all presented cards. In this mode, any card approaching the reader opens the door and also gets stored into reader's memory. This mode is used to recover the user database without need to collect all cards from the clients.

To enter this mode, a Master card is needed. Touch the reader with a Master card five times. On each touch, the controller issues beeps acknowledging the Master card touches, their number corresponding the number of touch. On fifth touch, the reader will issue five beeps and one long beep denoting transition to the Accept mode. To exit this mode, touch the reader with a Master card, the exit is acknowledged with a series of short beeps.

Note: In case of power failure, activated Accept mode will stay on after the power is back.

4.9. Free Pass Mode (Handle Down, 1B)

In the Free Pass mode, the lock becomes permanently open. This mode allows keeping the door open in emergencies, or for a certain time period (working day, break, conference, etc.)

To enter the Free Pass mode, hold the internal lock handle down, then touch and hold a Blocking card at the reader for ~ 3 s, until a long continuous beep sounds, -- that acknowledges the transition to Free Pass mode. Now the lock will open with just a turn of the handle, no card needed.

To exit the Free Pass mode and revert to Normal mode, either:

- a) Use a Blocking card in the same way as when entering Free Pass mode, until a series of short beeps;
- b) Touch the reader shortly with a Master card, until a series of short beeps.

Note: In case of power failure, activated Free Pass mode will stay on after the power is back.

5. HOTEL MODE: OPERATION AND PROGRAMMING

The Hotel Mode can work only under control of special software and Z-2 USB RF-1996 adapter installed on the computer. The software along with the Z-2 USB RF-1996 adapter allows to configure and set up the locks, issue and edit guests', staff, and special service cards, in the Hotel Mode.

Hotel Mode operation:

Stage 1. Designing the hotel security coverage plan.

Using the special software, design the plan for the hotel security coverage on the computer. Here we create the users, the doors, access times, and define who, when and through which doors will have access.

Stage 2. Configuring the locks.

The settings designed on Stage 1, have to be stored into locks by means of an Z-2 USB RF-1996 adapter. After the settings have been stored, the locks have defined:

- Door number;
- Current time;
- Access times;
- Staff access rules;
- Guest access rules;
- Special purpose cards usage rules;

Stage 3. Issuing the cards.

Now that the locks have been configured and have the hotel security coverage rules stored into them, we can issue the cards. Using the software and an Z-2 USB RF-1996 adapter, a computer user can store the following information to the cards:

- Starting and ending dates and times of card validity;
- Access open times for the card;
- The doors the card may open.

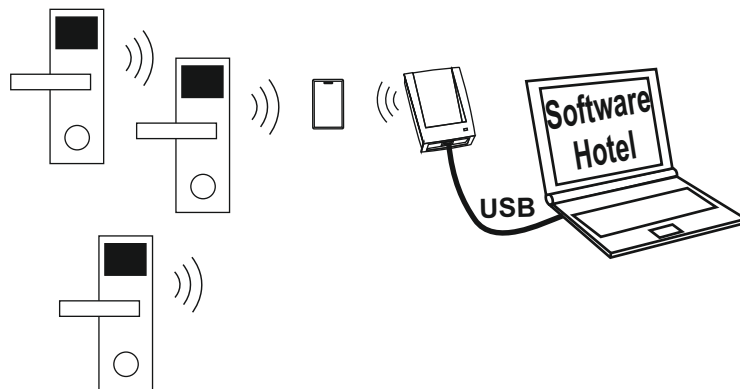

6. X1 SOCKET JUMPERS DESIGNATION

The X1 socket is installed on the reader's Printed Circuit Board (PCB). X1 socket allows setting the lock logic mode and editing the lock's keys memory. The lock is supplied with a jumper, its different positions on the X1 socket activate different lock functions (see Fig. 5).

Position 1 - changes the lock operational logic into the OFFICE mode. Power off the lock, set the jumper to Position 1 and restore power.

Position 2 - allows adding Normal cards in the OFFICE mode without a Master card. Power off the lock, set the jumper to Position 2 and restore power. A signal sounds and the lock enters Add Normal Cards mode. This mode ends automatically after 16 s after the last card touch. Now return the jumper to Position 1.

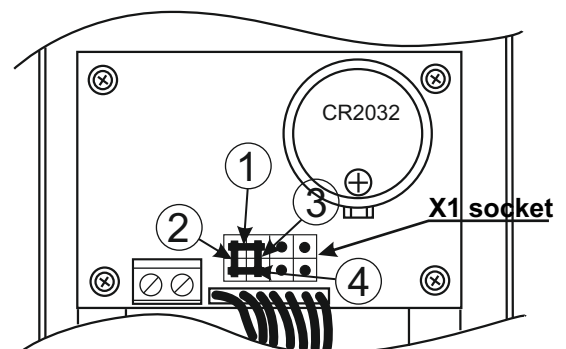

Fig.5

Position 3 - erases the lock's entire memory in the OFFICE mode. Power off the lock, set the jumper to Position 3 and restore power. When memory erasure completes, a series of short beeps sounds. Now return the jumper to Position 1.

Note: All Master and Normal cards as well as custom Door Release Time settings are erased. The Door Release Timer is reset to default value: 3 s.

Position 4 - changes the lock operational logic into the HOTEL mode. Power off the lock, set the jumper to Position 4 and restore power.

Note: When powering off the lock, also disconnect the CR2032 (button) battery installed on the lock PCB.

7. FIRMWARE UPDATE

The lock's firmware can be updated or replaced via Lock Commander software. Z-2 USB RF-1996 adapter is also required to download the new firmware into the lock. Depending on the firmware and model, the lock can operate:

- Stand-alone without software;
- Stand-alone with software.

The firmware available for the lock is found at the www.ironlogic.me website.

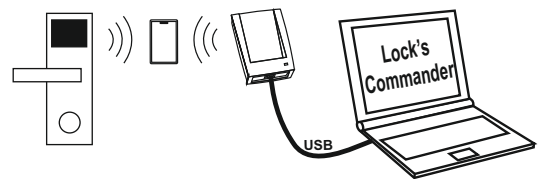

8. BATTERIES

Powered by four alkaline batteries with 1,500 mAh capacity, the lock is guaranteed to open at least 25,000 times, or stay working for 2.5 years in Standby mode. The lock monitors the battery charge level and informs the user with a visual signal when the discharged batteries need to be replaced, as follows:

Batteries that need replacement.

If the blue LED does not blink when the lock is approached with a card present in controller's database, the batteries need to be replaced, lest they fully discharge and the lock electronics stops working.

If the batteries could not be replaced timely and now they don't have energy to open the door by card, use the mechanical key supplied with the lock to open the door.

Batteries replacement.

To replace the lock's batteries, please refer to Fig. 7.

The lock's memory is non-volatile, so the settings and keys will survive batteries replacement.

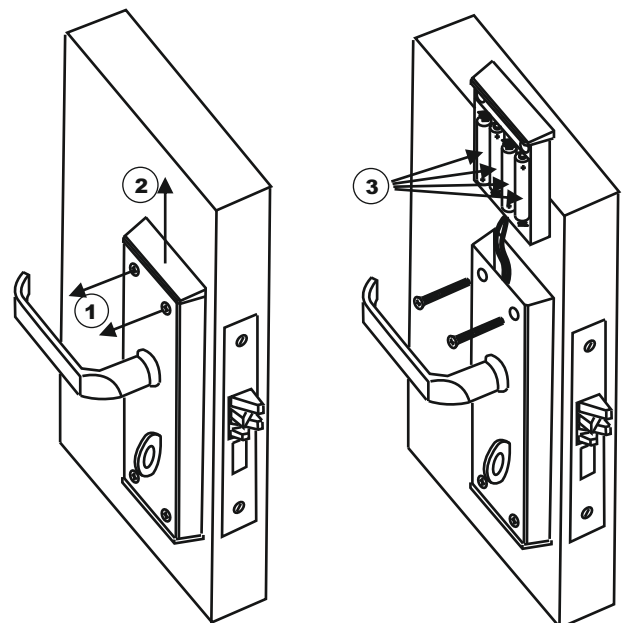
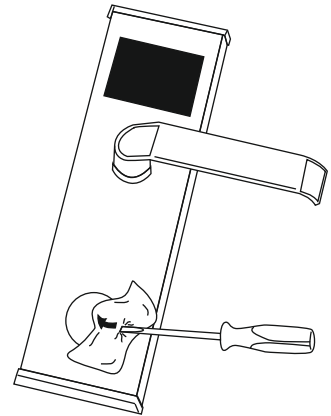

Fig.7

9. USING MECHANICAL KEYS

The lock can be opened with mechanical keys (two of these are supplied with the lock), without using contactless keys.

To open the lock with a mechanical key, insert a thin flat screwdriver between the lock body and the keyhole plug and drive the plug out. Protect the lock body from scratches by putting a cloth over screwdriver tip. Once the plug is out, use mechanical key on the lock's cylinder.



10. CONNECTING EXTERNAL DEVICES

- External lock release button.

- If necessary, the lock can be supplied with an external lock release button. Use the terminals found on the PCB to connect the button wires.

- When the external button is pressed, a beep sounds and the blue LED starts blinking. While it's still blinking, turn the lock's handle and open the door before the door release timer expires (default timer duration 3 s). The door release timer can be programmed within 0...220 seconds. (See Paragraph 4.6).

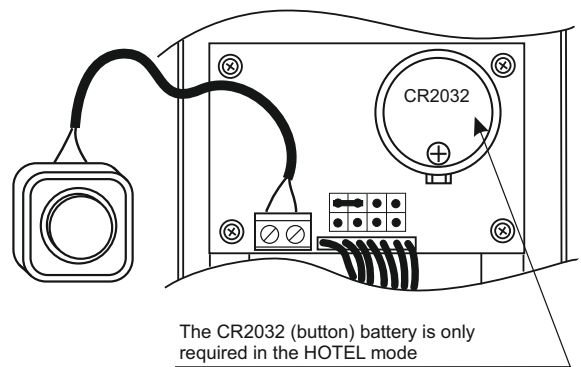

The CR2032 (button) battery is only required in the HOTEL mode

- RF-1996 adapter.

- The Z-2 USB RF-1996 adapter transfers data in a contactless way between the lock and a PC, via the reader antenna. It also can update the lock's firmware.

- At the bottom of Z-2 USB RF-1996 case, a sticker denotes its antenna position.

- To transfer the data, approach the adapter's antenna to the lock's reader antenna. For reliable data transfer, ensure the distance between the antennas is less than 3 cm.

- Fire Alarm.

- The lock can be connected to a fire alarm. When the fire alarm is activated, the lock enters the Free Access mode.

- To revert the lock into Normal mode, just approach it with a Master card.

- To connect a fire alarm, use the terminal on the lock's PCB.

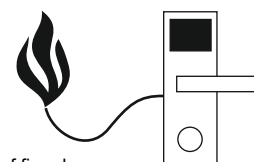
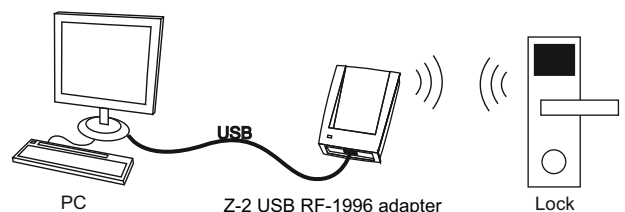

Relay output of fire alarm near the flame sign

Note: this modification requires lock firmware replacement.

11. ACCESSORIES

- **Z-2 USB RF-1996 Adapter**

- To configure and setup the locks on a PC and subsequent card programming in HOTEL mode.
- To create, delete and edit the keys in the database on a PC, and to transfer them to/from the locks in the OFFICE mode, in a contactless way through the lock's reader.
- To change the lock firmware.

- **Lock Commander software**

- To configure and setup the locks on a PC and subsequent card programming in HOTEL mode.
- To create, delete and edit keys in the database on a PC, and to transfer them to/from the locks in OFFICE mode, in a contactless way through the lock's reader.
- To support all the details of card issuing process and lock operation in HOTEL mode.

- **Base Z5R software**

- To create, delete and edit keys in the database on a PC, and to transfer them to/from the locks in OFFICE mode via the X1 socket.

- **Hotel software**

- To work with the locks in HOTEL mode.
- To issue and edit guests' cards, staff cards and special purpose cards.

- **Z-2 USB EHR Adapter**

- To create, delete and edit keys in the database on a PC, and to transfer them to/from the locks in OFFICE mode via the X1 socket.

- **Lock assembly**

- To replace the mechanical part of the lock.

- **Tokens (Cards/Key fobs/Bracelets)**

- Contactless tokens for the lock.

12. PACKAGE CONTENTS

-Z-7 EHT Lock:1

13. OPERATING CONDITIONS

Ambient temperature: -30...40°C.

Humidity: ≤ 98% at 25°C.

When operating under non-recommended conditions, device parameters can deviate from specified values.

The reader must be operated in absence of: precipitation, direct sunlight, sand, dust, and moisture condensation.

14. LIMITED WARRANTY

This Device is covered by limited warranty for 24 months.

The warranty becomes void, if:

- this Manual's guidelines are not followed;
- the device has suffered physical damage;
- the device has visible traces of exposure to moist and/or aggressive chemicals;
- the device circuits have visible traces of tampering by unauthorised parties.

Under this warranty, the Manufacturer shall repair the device or replace any broken parts as required, free of charge, in cases where the fault is caused by a Manufacturer's defect.

15. CONTACTS

Authorized representative in the European Union:

ICONTROL SIA

1B Balta Street, LV - 1055, Riga, Latvia

E-mail: info@icontrol.lv

Phone: +371 24422922

www.icontrol.lv



The symbol of crossed-through waste bin on wheels means that the product must be disposed of at a separate collection point. This also applies to the product and all accessories marked with this symbol. Products labeled as such must not be disposed of with normal household waste, but should be taken to a collection point for recycling electrical and electronic equipment. Recycling helps to reduce the consumption of raw materials, thus protecting the environment.

