

F780 Drilling & Installation Guide

Installation Procedure

Fig. 1:

- 1、 Drill a hole of 38mm diameter in the door from the door edge of 41mm;
- 2、 Put the plug through the fixing plate and the door hole and insert into the socket of the front panel;
- 3、 Put the fixing plate on the bottom of the front panel and fix with 2 M3X12 screws ;
- 4、 Fix the rear panel on the door with 2 ST3X12 screws;
- 5、 Load 3 pcs AA alkaline batteries into the battery holder and insert the battery cover to fix it.

Fig.1

Fig. 2:

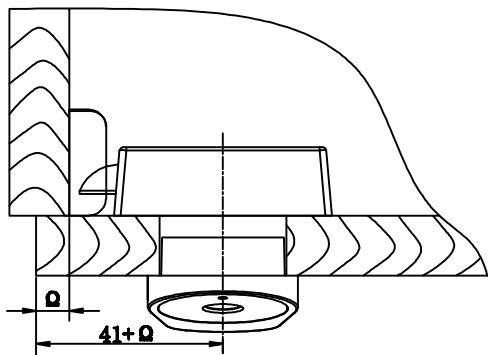

Fig.2

Fig. 3:

- 1、 Fix the latch-stopper on the door frame with 3 ST3.5X20 screws.

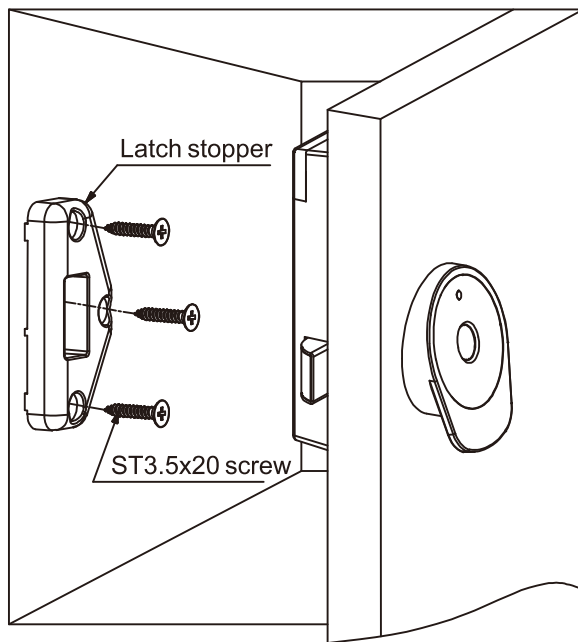

Fig.3